

Improved Absorber-Stripper Technology for Gas Sweetening to Ultra-Low H₂S Concentrations

G.P. TOWLER, H.K. SHETHNA,
UMIST,
Manchester, United Kingdom

B. COLE, B. HAJDIK,
Bryan Research & Engineering, Inc.,
Bryan, Texas

ABSTRACT

The removal of trace components from a gas by absorption using a chemical solvent is of importance to the gas processing industry. There is a growing interest in reaching lower outlet concentrations for reasons of health and safety; however, this requires very high energy use for solvent regeneration. Instead, solid-adsorption-based processes are often used as a secondary treatment step. We have developed new processes for liquid absorption that exploit better understanding of the thermodynamics of chemisorption processes in mixed solvent systems. The new processes use any conventional solvent and incorporate recycles between the absorber and stripper, by means of which the thermodynamic and process conditions for stripping are optimized to reduce the process heat requirement at high separation efficiency. Using these new processes it is possible to reach sub-ppm concentrations of acid gas with considerable savings in energy costs and without requiring use of solid sorbents. The new technology is based on conventional vapor-liquid contacting equipment and is suitable for retrofit to existing plant.

Proceedings of the Seventy-Sixth GPA Annual Convention. Tulsa, OK: Gas Processors Association, 1997: 93-100.

[Bryan Research & Engineering, Inc.](#)

Visit our Engineering Resources page for more articles.

INTRODUCTION

Chemical absorption of gas-phase compounds into a liquid sorbent is an important industrial process. Examples of this process include recovery of hydrogen sulfide and carbon dioxide from acid gases such as natural gas, refinery gas and coke-oven gas using aqueous alkanolamine solutions, and absorption of sulfur dioxide using alkali metal sulfite-bisulfite solutions.^{1,2} The solvents for such processes are chosen such that the absorption step can be reversed by changing the conditions of temperature and pressure. Absorption takes place at high pressure and low temperature, giving high loadings of absorbed component in the solvent. The solvent is then sent to a regenerator, which operates under conditions of high temperature and low pressure, causing desorption of the absorbed components and regenerating the solvent. Heat is added in the regenerator to provide for the heat of reaction, the sensible heat change of the solvent, and to generate a vapor flow for stripping by partially reboiling the solvent.

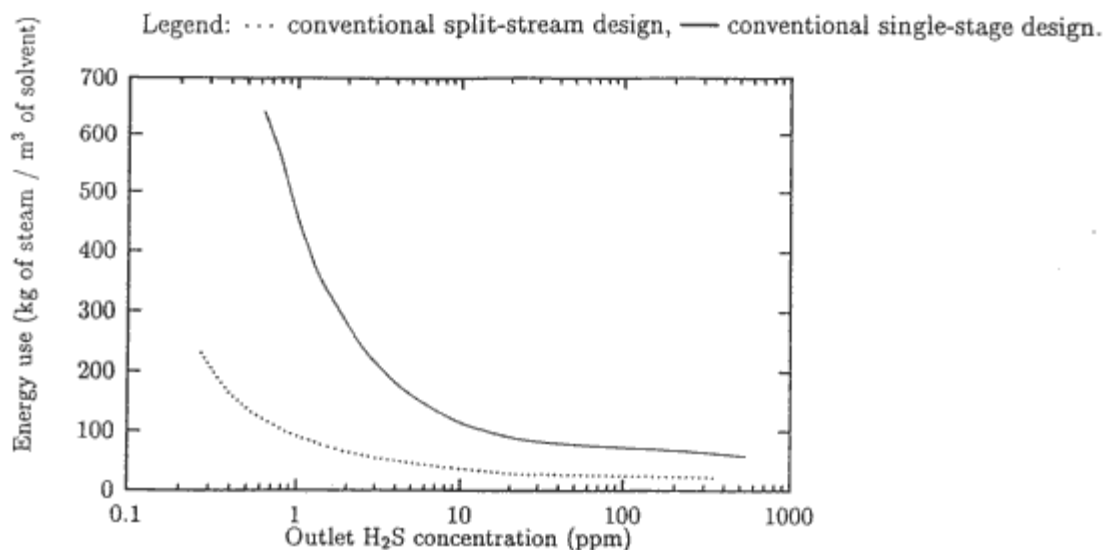

Figure 1. Typical plot of the variation of outlet H₂S consumption with energy use for the conventional single-loop design and the conventional split-loop design.

Alkanolamine absorption processes are efficient for bulk acid gas removal to concentrations up to about 10 ppm, but for lower outlet concentrations the energy required for stripping increases rapidly, Figure 1. Because of this, processes based on adsorption onto a solid sorbent are usually used to recover the last few ppm of acid gas.³ These processes can be reversible, for example, pressure-swing-adsorption, or irreversible. The reversible processes have the advantage that they can process a much larger volume of gas before the bed must be replaced and they can tolerate higher inlet concentrations of acid gas than the irreversible processes. They face the disadvantage that they generate a low-pressure off-gas that requires further treatment before it can be emitted. The irreversible processes are usually cheaper to install, allow greater flexibility, and can achieve very low outlet concentrations, but they must be fed with a gas containing a low fraction of acid gas, otherwise the bed is saturated too quickly, and they produce solid waste that is not always suitable for regeneration.⁴

There is considerable interest in treatment of natural gas to achieve lower H₂S specifications for pipeline distribution. Studies in the UK have shown that there is a link between pipeline H₂S concentrations and the failure of gas metering and supply equipment.⁵ This poses a potential health and safety risk, and it has therefore been suggested that the pipeline specification for natural gas in the UK should be lowered from 3ppm to 1ppm.⁶ This has created a need for the development of technology that will allow the lower H₂S specifications to be reached by making simple modifications to existing equipment, without the installation of an additional plant, and with no new negative impacts on the environment. LNG production also requires CO₂ removal to very low levels.

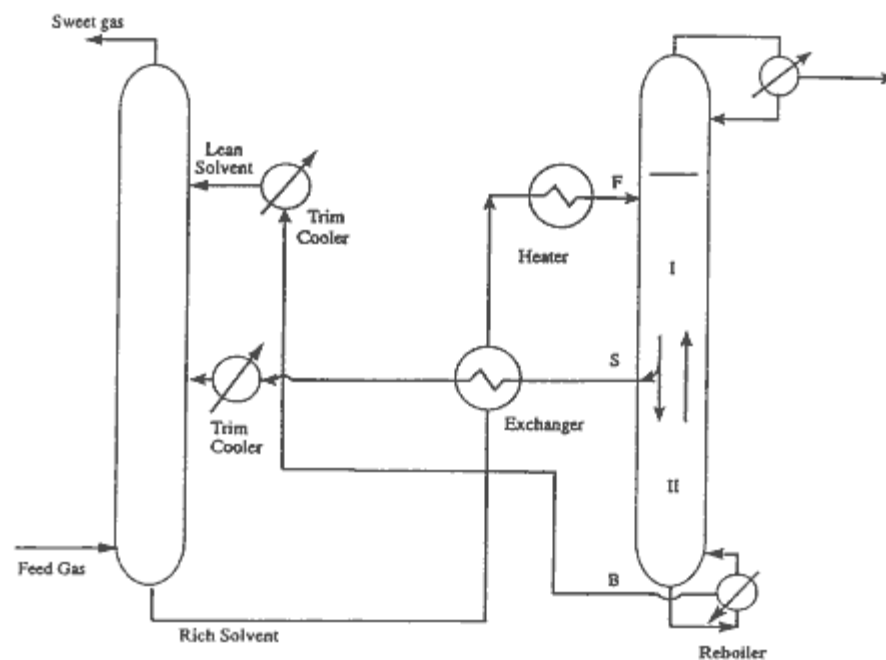

Figure 2. Conventional split-stream absorber-stripper arrangement.⁹

Several process arrangements have been developed to reduce energy use.^{7,8} As early as 1934, Shold proposed a split-loop absorption cycle, in which the bulk of the solvent is removed from an intermediate stage of the stripping column and recycled to an intermediate stage of the absorber, Figure 2.⁹ In this arrangement only a small portion of the solvent is stripped to the lowest concentration, and a high vapor to liquid ratio for stripping is achieved in the bottom trays of the absorber. This results in lower energy use at low outlet concentrations; however, the reductions in energy use are not enough to make split-loop absorption cheaper than alternative processes and split loop cycles have consequently not found much application in industry.^{10,11} This poor performance is largely due to thermodynamic inefficiencies in stripping, which will be addressed in this paper. By recognizing that thermodynamic inefficiency results from variations in the solvent composition as it circulates within the split loop, we are able to propose new designs that permit economic absorption to sub-ppm levels. These designs will be illustrated using the example of absorption of H_2S and CO_2 from natural gas.

SIMULATION METHODS

This work required study of different process configurations for absorption of H_2S under industrial conditions. Since such studies would be difficult and expensive to carry out on an industrial plant or laboratory scale model, the processes were instead modeled using commercial simulation software provided by Hyprotech Ltd. (HYSIM) and Bryan Research and Engineering (TSWEET). A discussion of the assumptions used in these models and the approximations introduced into the analysis by use of modeling in place of experimentation is given by Shethna.¹²

Both of these simulation packages have been industrially validated, although TSWEET is more widely used in the gas processing industry. Care was taken to evaluate the performance of both simulators in predicting the absorption equilibrium at low concentrations of H_2S and CO_2 by comparison with experimental data. Both programs use thermodynamic models based on that developed by Kent and Eisenberg, though each has been fitted using proprietary data.¹³ It was found that both programs tend to slightly overestimate the H_2S partial pressure at concentrations below 1ppm; therefore, both programs will underestimate the energy that is required for stripping at very low outlet concentrations. Since we are primarily interested in comparison between different absorption flowsheets, this error is not of concern, as it will affect all of our results equally; however, it should be taken into account if a comparison between absorption and adsorption processes is made.

CONCENTRATION BEHAVIOR OF MIXED SOLVENT SYSTEMS

Phase equilibrium of mixed solvents

The design of chemisorption processes requires a clear understanding of the equilibrium between the solvent and the dissolved gas. In general, the solvent consists of an active component, such as an alkanolamine, together with diluents, physical sorption promoters and corrosion inhibitors. Because of the presence of these additional components the solubility of the dissolved gas (solute) is usually given in moles of solute per mole of active sorbent (known as solvent loading). At constant solute partial pressure, the solubility of the dissolved gas varies with the liquid concentration of the active component. For example, Figure 3 shows the partial pressure of H₂S over methyldiethanolamine (MDEA) solutions of different concentration. It is clear from this figure that the more concentrated MDEA solution exerts a higher partial pressure at the same solvent loading.

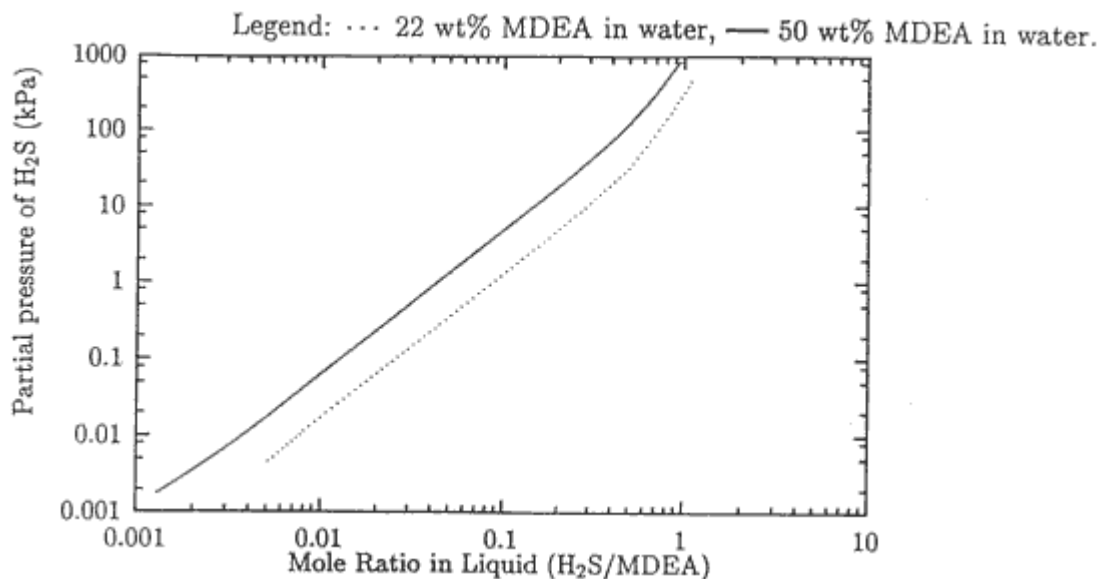

Figure 3. Partial pressure of H₂S vs. mol ratio of H₂S to alkanolamine for different alkanolamine concentrations at 40°C as obtained from acid-gas equilibrium calculation using flash stages.

In designing an absorption process, we wish to achieve a specified outlet concentration of the absorbed component in the absorber column. To achieve this, it is necessary that the stripped solvent leaving the regenerator must contain a concentration of solute less than that which would be in equilibrium with the gas leaving the absorber at the conditions at the top of the absorber column. The design problem therefore specifies a required solvent loading for the regenerated solution. Since a solution that contains a higher concentration of active component exerts a higher partial pressure of solute, it is easier to strip such a solution to achieve the required solvent loading. Thus a high concentration of active sorbent improves the efficiency of stripping. Since regeneration is the most energy-intensive stage in the process, the usual choice is to operate with the highest possible concentration of active sorbent, subject to the constraints imposed by corrosion.

Variation of concentration in absorber-stripper processes

Significant variation in solvent concentration occurs during stripping. The vapor for stripping is generated by reboiling the solvent, and becomes enriched in the more volatile components of the solvent. For example, in aqueous alkanolamine systems the vapor is almost entirely water, because of the lower volatility of the alkanolamines. Some of this vapor condenses inside the column to provide the heat of desorption and sensible heat of the liquid. Since the bulk of desorption occurs on the top few trays of the stripper column, this condensation can be considered to occur almost entirely on the trays immediately below the liquid feed. The remainder of the vapor is usually recovered in an overhead partial condenser and returned to the process to control the solvent concentration. Typically this is achieved by refluxing the condensate to the stripper column. This reduces the condenser duty, but also reduces the solvent concentration in the stripper, and consequently gives a less than optimal concentration of solvent for regeneration. Alternatively, the condensate can be recycled to the stripper column reboiler. This maintains a higher concentration of alkanolamine in the stripper, which

improves regeneration performance in single-loop absorber-stripper processes.

In split-loop processes, the variation of solvent composition is further complicated by the presence of the side-draw from the stripper column. Referring to Figure 2, the solvent in streams S and B must be in mass balance with the solvent in feed F. Since the bulk of vapor condensation occurs in region 1 of the regenerator, the side stream S will be enriched in the more volatile components of the solvent (typically water) and consequently the bottom stream B will be depleted. In the case of alkanolamine absorption, this means that the bottom stream will have the maximum concentration permitted, while the feed and side streams will be more dilute. This reduces stripping efficiency and causes an increased overall solvent flow, as the carrying capacity of the bulk solvent is also reduced. This increased solvent flow has been observed experimentally, although they did not comment on the cause.¹¹

IMPROVED PROCESS FOR SPLIT-LOOP ABSORPTION

The conventional split-loop absorption process can be considerably improved by altering the design to give better control of the solvent concentration, in order to achieve the optimum conditions for regeneration. These improvements become particularly beneficial as we seek to achieve lower outlet concentrations of the absorbed component. Two modifications are necessary. The first is to control the composition of the side stream leaving the stripper column by placing a reboiler on this stream to boil off enough water to maintain the same concentration in the side stream and bottom stream. The vapor generated by this reboiler can be returned to the upper section of the stripping column. This eliminates the change in concentration due to condensation in the upper section of the column. Increasing the side stream concentration (and hence the bulk solvent concentration in the stripper feed) increases the solution loading at the bottom of the absorber, and hence the overall solvent circulation is reduced. In processes using MDEA in water as solvent, this modification typically reduces the liquid circulation by 20 %.

Further improvements can be made by designing the stripper to create optimum concentration conditions for regeneration. As stated above, the condensate must be returned to the system to maintain the solvent concentration. If the condensate is refluxed to the stripper column then the concentration of alkanolamine in the liquid in the stripper column will be reduced, reducing the partial pressure of H_2S and hence reducing stripping efficiency. Instead, if the condensate is returned to a lower point in the column then the liquid on the trays above that point will be at the optimum condition for stripping. The best option is therefore to return the condensate to the lowest point possible in the stripper column, i.e., to the column reboiler. In split-loop processes, however, direct return of the condensate to the reboiler is not desirable, as the condensate will generally be saturated with H_2S and returning it directly to the reboiler causes undesirable back-mixing, reducing the outlet concentration of solute achieved. Instead, the dissolved gas concentration in the condensate can be reduced by returning the condensate to the column a few stages above the solvent feed, and then removing the condensate from the column instead of allowing it to flow down into the stripper. This partially strips the condensate and allows some direct heat transfer between the condensate and the stripper off-gas, reducing the duty of the condenser. This gains all the advantages of refluxing the condensate to the column without the disadvantage of producing a sub-optimum concentration on the stripping stages. If very low outlet concentrations of acid gas are required, the condensate can be further stripped using a small amount of steam injection in a side stripper column, prior to recycle to the stripper reboiler. If live steam is used, the process water balance is maintained by taking a water effluent from the condensate or from the glycol drying unit that typically follows acid-gas removal.

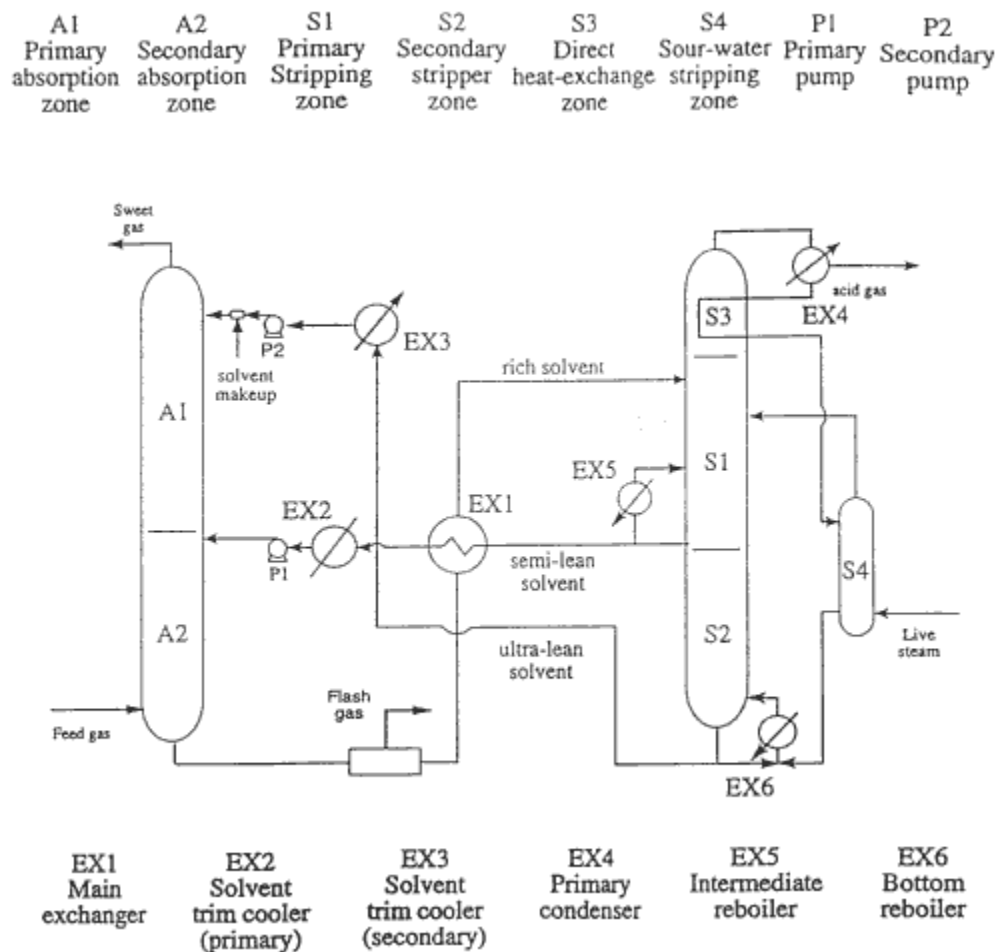

Figure 4. A new flow scheme for chemisorption with ultra-high recovery, thermodynamically efficient regeneration system.

A modified split-loop process embodying these modifications is illustrated in Figure 4. The condensate from partial condenser EX4 is sent to the top section S3 of the stripper column, where it undergoes partial stripping, and is then further stripped to a very low concentration of dissolved gas in side-stripper S4, before being returned to the stripper bottom reboiler EX6. The intermediate reboiler EX5 is used to maintain the same concentration of solvent in the bottom stream and side stream. Only a small portion of the total solvent (typically less than 20%) is stripped to the ultra-low concentration, thus allowing the process to achieve low outlet concentrations with low energy use. The performance of this process will be discussed below.

NEW SPLIT-LOOP PROCESS USING VAPOR SUBSTITUTION

Shethna and Towler showed that as the outlet gas concentration of an absorber-stripper process is reduced to very low values the incremental heat requirement is almost entirely used to generate vapor flow in the stripper column.¹⁴ This results from the non-linear behavior of the vapor-liquid equilibrium in chemisorption processes. The reboiler heat duty can be reduced by substituting a different vapor for solvent boil-up. An attractive possibility is to use a small recycle of the lean gas from the top of the absorber column, since this gas is almost completely free of H₂S. If the sections of the stripping column are separated then this recycle gas can be returned to the process feed or put to some other use, depending on the process and site conditions.

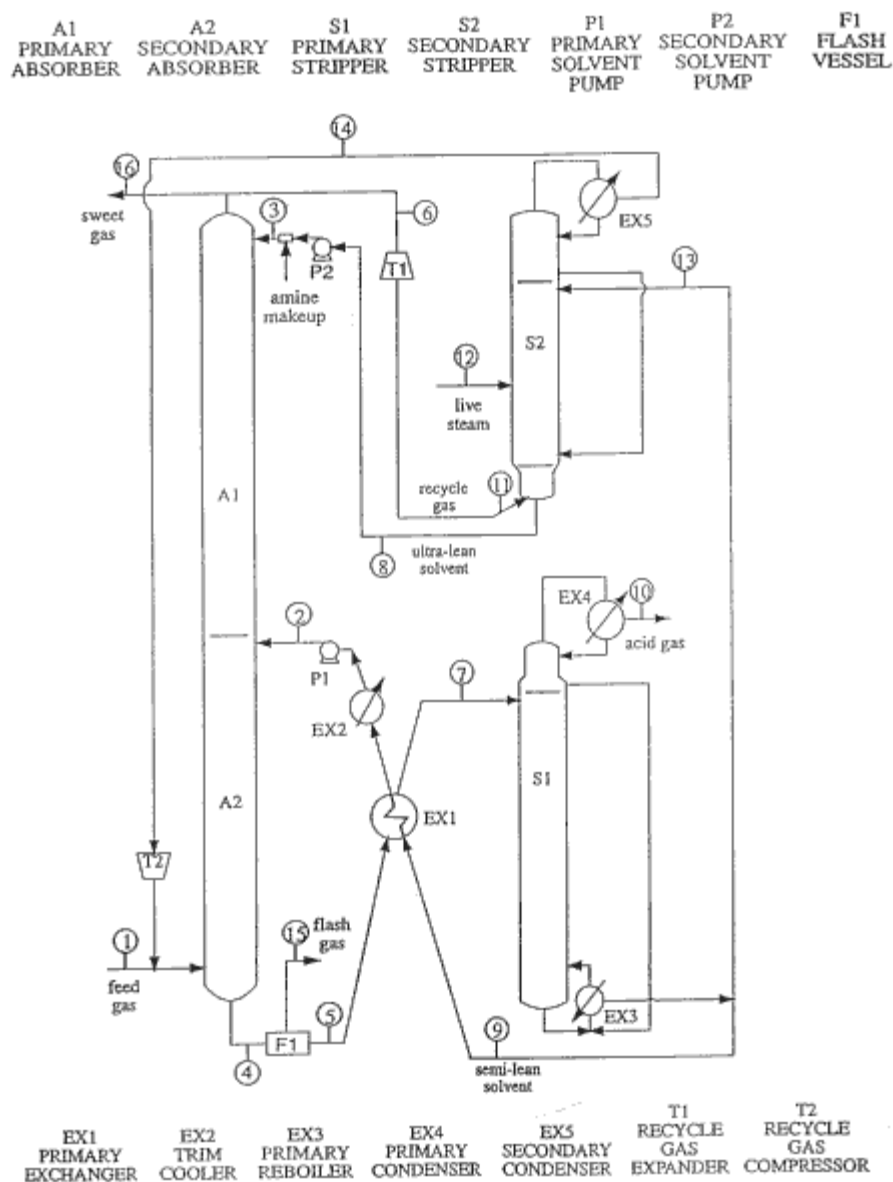

Figure 5. The double-loop absorber-stripper process using recycle gas as the stripping medium.

Figure 5 shows a process based on the concept of vapor recycle, containing an absorber column with two sections, similar to the absorber column of a split-loop process. The bulk of the absorption takes place in the bottom section, A2, using a partially-stripped solvent. The solvent leaving the absorber is flashed to recover dissolved hydrocarbons and then heated and sent to the primary stripper, S1. The flash stage is not always necessary, depending on how much hydrocarbon material undergoes physical absorption in the solvent in the absorber, and also depending on the destination of the H₂S after stripping. The stripper S1 partially regenerates the solvent, achieving an outlet solute concentration typical of conventional single-loop processes, and the bulk of the solvent leaving stripper S1 is returned to section A2 of the absorber. Only a small fraction of the solvent from S1 is sent to the secondary stripper S2 for further stripping.

About 1% of the treated gas leaving the absorber is used to provide a vapor source for stripper S2. This gas is expanded to the pressure of stripper column S2, which causes cooling of the gas, so that it can undergo direct heat exchange with the liquid on the bottom trays of S2, cooling the ultra-lean solvent and eliminating a heat exchanger. If the process requires a water make-up then a small amount of live steam can be added to the stripping gas. The liquid in column S2 is stripped to a very low concentration and is then sent to the top section of the absorber column, A1, to achieve polishing of the process feed gas. The gas leaving S2 is cooled to recover condensate and is then recycled. There are several options for processing this gas, for example, it can be compressed and returned to the process feed, as shown in Figure 5, or else it can be used as the fuel source for

a Claus process tail-gas unit or integrated with other downstream or upstream processes.

There are a number of ways in which this process can be advantageously combined with fixed-bed irreversible absorption technology. For example, the recycle gas can be passed over a bed of solid sorbent to remove H_2S prior to combustion. This substantially reduces the flowrate of gas and the acid gas concentration that must be treated in the fixed bed, thus ensuring a long bed life. Sorbent beds can also be used to guarantee achievement of ultra-low outlet concentrations during start-up and plant upsets. A further advantage of incorporating fixed-bed absorption processes is that they can remove COS, allowing total removal of sulfur if required.

An additional advantage of this design is that the use of a substitute vapor instead of reboiled solvent lowers the partial pressure of solvent vapor in the column and allows the secondary stripper column S2 to operate at a lower temperature than the primary stripper S1. This reduces the corrosivity of the solvent and might allow the use of cheaper materials of construction such as carbon steel in place of the conventional stainless steel.¹

It would be relatively straightforward to consider retrofit of an existing plant to this new design. The bulk absorption stages of the split-loop design behave similarly to a conventional single-loop absorber and the flows in the polishing section are small. It is therefore possible to use the existing plant for the bulk separation stages. It may be necessary to re-tray the top stages of the absorber to allow for the reduction in liquid flow that will occur. The additional equipment needed is limited to a small secondary stripping column and any other equipment associated with the gas recycle. The compressor shown in Figure 5 may not be necessary, depending on the use of the recycle gas.

CASE STUDIES

Methods for the design of modified split-loop absorption processes have been described by Shethna and Towler.¹⁴ Optimized computer simulations of the split-loop processes can be generated in a few hours if a good initialization is made using the shortcut design procedures described by Shethna.¹² The performance of the different flowsheets presented above will be illustrated through two case studies. The first of these is non-selective removal of H_2S from 4 mol% to 0.25 ppm in the presence of 2 mol% CO_2 in CH_4 , and the second is selective removal of H_2S from 2 mol% to 4 ppm in the presence of 15 mol% CO_2 in CH_4 . In both cases the feed was taken as 5000 kmol/hr at 35°C and 40 bar, and the solvent used was 50 wt% MDEA in water. Although MDEA is primarily used for selective absorption, absorption of CO_2 is also possible if monomethyl-monoethanolamine or piperazine is used as an absorption activator.¹⁵ Annualized costs for the process equipment were calculated based on correlations given by Douglas.¹⁶ Details of the assumptions made in costing the processes are given by Shethna.¹² In both cases the new designs are compared with conventional flowsheets, although it should be noted that for the non-selective case it is not possible to achieve an outlet concentration of 0.25 ppm H_2S using single-loop absorption. The results for this process are therefore given for an outlet concentration of 10 ppm, and it is assumed that an additional polishing process would be necessary. The costs of such polishing processes cannot be assessed accurately using data available in the literature.

Process	Single-loop absorption	Conventional split-stream (Figure 2)	New scheme I (Figure 4)	New Scheme II (Figure 5)
H ₂ S Specification (ppm)	10	0.25	0.25	0.25
Energy use (kg steam/m ³ solvent)	117.7	273.8	82.0	89.5
Solvent flow (m ³ /hr)	162.1	193.22	167.9	167.0
Power use (kw)	234.4	272.2	233.8	404.2
Annual energy cost (M\$)	1.25	2.71	0.91	1.05
Annualized capital cost (M\$)	0.97	1.52	0.89	1.12
Capital breakdown (M\$)				
Columns	0.43	0.74	0.33	0.48
Exchangers	0.54	.78	0.56	0.41

Compressor	0	0	0	0.23
Total annualized cost (M\$)	2.22	4.23	1.8	2.16

Costs for the non-selective absorption case are given in Table I, from which it can be seen that the conventional split-stream absorption process is substantially more expensive than single-loop absorption to 10 ppm, confirming that conventional split-loop absorption is uneconomic compared to single-loop absorption followed by a polishing process based on adsorption. Both new processes are significantly cheaper than the conventional split-stream process, mainly due to the reduction in solvent flow and energy use. In this particular case, the modified split-loop design of Figure 4 is the cheapest, although in other cases the gas-recycle design of Figure 5 is better.

In the selective removal case, Table II, the three designs achieve roughly the same selectivity of H₂S removal over CO₂, but the energy use of the new split-loop processes is considerably less than that of the conventional single-loop process, as a result of the improvement in the thermodynamic efficiency of stripping. This reduction in energy costs leads to savings of almost 30 % in total annualized cost. For the selective removal case the benefits of using the modified split-loop processes are even greater than in the non-selective absorption case.

CONCLUSIONS

Two new designs for absorption processes have been introduced, based on improved understanding of the solvent behavior in stripping processes. By creating the optimum conditions for stripping it is possible to achieve significant reduction in process energy use, which allows ultra-low outlet concentrations to be achieved using absorption alone. The first new design is a modification of the conventional split-loop process that allows better control of the solvent composition. The second is an entirely new process, in which solvent polishing is achieved by recycle of a small portion of the treated gas. The case studies presented showed that these processes have significant cost advantages relative to the conventional technology.

ACKNOWLEDGEMENT

This research was funded by the members of the UMIST Process Integration Research Consortium. The authors are grateful to Hyprotech Ltd. and Bryan Research and Engineering for providing academic licenses of their software.

REFERENCES

1. Kohl, A. and Riesenfeld, F., *Gas Purification*, Gulf Publishing Co., Houston, 1985.
2. Bailey, E.E. and Heinz, R.W., "SO₂ Recovery Plants - Materials of Construction", *Chem. Eng. Prog.*, 71(3): 64-68, 1975.
3. Collins, C., Durr, C.A., de la Vega, F.F. and Hill, D.K., "Liquefaction Plant Design in the 1990s", *Hydr. Proc.*, 74 (4): 67-76, 1995.
4. Carnell, P.J.H., Joslin, K.W. and Woodham, P.R., "Fixed-bed Processes Provide Flexibility for COS, H₂S Removal", *Oil & Gas J.*, 93(23): 52-55, 1995.
5. Wilson, G., Gas Works Assoc., District Councils Rev., 10, July 1995.
6. Jones, A., "Safety Aspects of Hydrogen Sulphide Concentration in Natural Gas", HSE Consultative Document, HMO Publishers, London, 1996.

7. Sigmund, P.W., Butwell, K.F. and Wussler, A.J., "HS Process Removes H₂S Selectively", *Hydr. Proc.*, 60(5): 118-124, 1981.
8. Benson, H.E. and Parish, R.W., "Hipure Process Removes CO₂ and H₂S", *Hydr. Proc.*, 53(4): 81-82, 1974.
9. Shoeld, M., "Purification and Separation of Gaseous Mixtures", U.S. Patent 1,971,798, 1934.
10. Wang, M. and Wei, S., "Energy Conservation of Absorption-Stripping Processes with Split-flow Cycles", *J. Chin. Inst. Chem. Eng.*, 15(1): 111-120, 1984.
11. Wang, M., Chang, R., Cheu, T., "Analysis of Absorption-stripping Processes with Split-flow Cycles for Energy Saving", *J. Chin. Inst. Chem. Eng.*, 16(1): 1-9, 1985.
12. Shethna, H.K., *Thermodynamic Analysis of Chemisorption Systems for Acid-gas Removal*, PhD. Thesis, UMIST, Manchester, United Kingdom, 1996.
13. Kent, R.L., and Eisenberg, B., "Better Data for Amine Treating", *Hydr. Proc.*, 55(2): 87, 1976.
14. Shethna and Towler, "Gas Sweetening to Ultra-low Concentrations Using Alkanolamine Absorption", Paper No. 46f, AIChE Spring Meeting, New Orleans, 1996.
15. Meissner, R.E. and Wagner, U., "Low Energy Process Recovers CO₂", *Oil & Gas J.*, 81(5): 55-58, 1983.
16. Douglas, J.M., *Conceptual Design of Chemical Processes*, McGraw-Hill, New York, 1988.

copyright 2001 Bryan Research & Engineering, Inc.