

AN ANALYSIS AND PREDICTION OF HYDROCARBON DEW POINTS AND LIQUIDS IN GAS TRANSMISSION LINES

Todd Dustman
Jeff Drenker
Questar Pipeline Company
Salt Lake City, UT

David F. Bergman
BP America, Inc.
Houston, TX

Jerry A. Bullin
Bryan Research & Engineering, Inc.
Bryan, TX

ABSTRACT

The occurrence of liquid hydrocarbons in natural gas transmission lines has increased in recent years as a result of the shrinking price spread between natural gas and natural gas liquids (NGL's). Consequently, there is increasing interest among many pipeline companies in monitoring hydrocarbon dew point (HCDP) and liquids in the transmission lines to ensure the safety and reliability of the system. This paper examines the methods available for determining the HCDP of natural gases and their implementation in transmission systems. A case study is presented on Questar Pipeline Company's management and control of HCDP issues in their interstate gas transmission system in Utah, Wyoming and Colorado.

AN ANALYSIS AND PREDICTION OF HYDROCARBON DEW POINTS AND LIQUIDS IN GAS TRANSMISSION LINES

INTRODUCTION

In recent years, there has been increasing interest in liquid hydrocarbon formation in gas transmission lines. Some pipeline companies have attempted to address the problem through a hydrocarbon dew point (HCDP) tariff specification. In any event, many pipeline companies are interested in monitoring HCDP and liquids in the transmission lines to ensure the safety and reliability of the system. Hydrocarbon liquids in distribution systems can be carried from main transmission lines or can result from retrograde condensation downstream of the pressure regulating station and the corresponding Joule Thomson (JT) cooling effect. Liquids can cause problems such as flame extinguishing or overfiring in furnaces or damage to gas turbines. In addition to safety considerations, liquids in transmission lines lead to higher pipeline pressure drops, higher compressor energy consumption, and reduced line capacity.

The occurrence of liquid hydrocarbons in transmission lines has become much more prevalent in recent years due to rising natural gas prices relative to natural gas liquids (NGL's). Historically, the markets for both natural gas and NGL's have been quite volatile. There have been several periods over the past five years where the price spread between natural gas and NGL's on a thermal basis has shrunk to the point where producers and processors have reduced or even stopped processing to remove NGL's. This action has resulted in the introduction of additional heavier hydrocarbons into downstream pipelines. As a consequence, both pipelines and downstream customers on pipelines have been experiencing free hydrocarbon liquid formation in their facilities.

The analysis and prediction of hydrocarbon dew points and liquids in transmission lines has been discussed in the literature for several decades (Bergman, et al [1], Warner, et al [2], NGC-GPA White Paper [3], GPA-Issue Brief [4], Fatica [5] and Ernest & Pettigrew [6]). The concept of HCDP, retrograde condensation and formation of liquid is most easily understood by referring to a typical phase diagram as shown in Figure 1. The theoretical HCDP is any point along the dew point line in Figure 1 when moving from the gas phase to the first small drop of liquid. The cricondentherm is the maximum temperature at which hydrocarbon liquids could occur (maximum HCDP). Also shown in Figure 1, retrograde condensation can occur when the dew point line is encountered between the critical point and the cricondentherm.

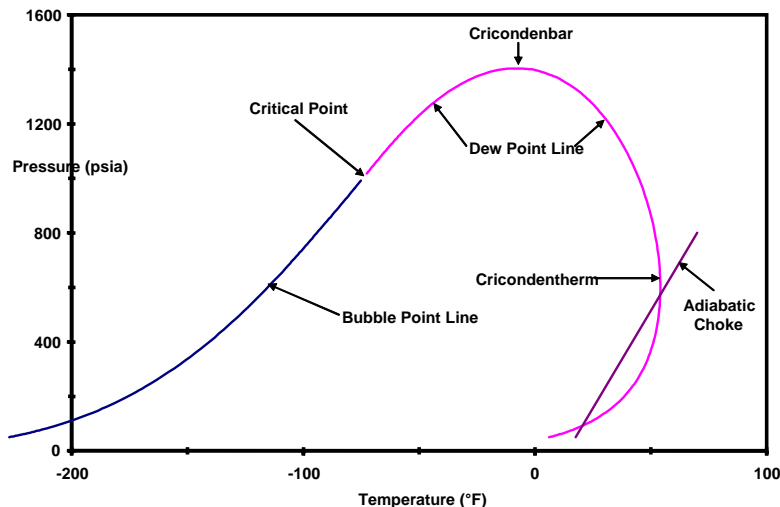

Figure 1 - Phase Envelope for a Lean Natural Gas

In this paper, the question of “How much liquid is too much?” is addressed. In addition, methods used to determine the HCDP are presented and discussed. Also presented in this paper is a description of how Questar Pipeline Company uses HCDP determination to manage liquid fallout on its system as well as to deliver “spec” gas to downstream pipelines. Included as part of the case study is an evaluation of HCDP using the chilled mirror method compared to compositional analysis by gas chromatograph combined with an equation of state (EOS). Two compositional analyses were obtained using a C₉₊ analysis and an extended analysis. Also, a third composition, modified C₆₊ characterization, was obtained by redistributing the data from the C₉₊ analysis. The HCDP evaluation is based on field derived gas samples from actual producing sources.

HOW MUCH IS TOO MUCH?

As discussed by Warner, et al [2], NGC-GPA White Paper [3] and Voulgaris, et al [7], the concept of a practical HCDP is needed and the question then becomes “How much liquid is too much?” Due to the types of facilities generally available, this question needs to be addressed separately for transmission lines and distribution lines.

Transmission Lines

Since most transmission lines have at least moderate separation capabilities, the primary impact of liquids is increased pressure drops, increased compression costs, more frequent pigging and decreased throughput. As a practical matter, most pipelines will usually have a small amount of hydrocarbon liquids from compressor oils. Additional liquids would be formed by retrograde condensation any time the HCDP is reached through cooling or dropping pressure. The volume of additional liquids depends on the amount and composition of the C₆₊. The impact of the C₆₊ content on the HCDP is shown in Figure 2 for a typical lean gas assuming that all of the C₆₊ is a single compound ranging from C₆ to C₁₂. For example, a gas could have a very small amount of C₆₊ that was primarily a C₁₂ yielding a high HCDP with very little liquids. The most convenient way of getting a feel for the amount of liquid that might condense is to look at the quality lines on a phase diagram. An example of this is shown in Figures 3a and 3b for two gases with essentially the same dew point line but with quite different amounts of liquids condensing upon further cooling beyond the HCDP. Thus, one would expect more problems with the gas that dumped larger amounts of liquids.

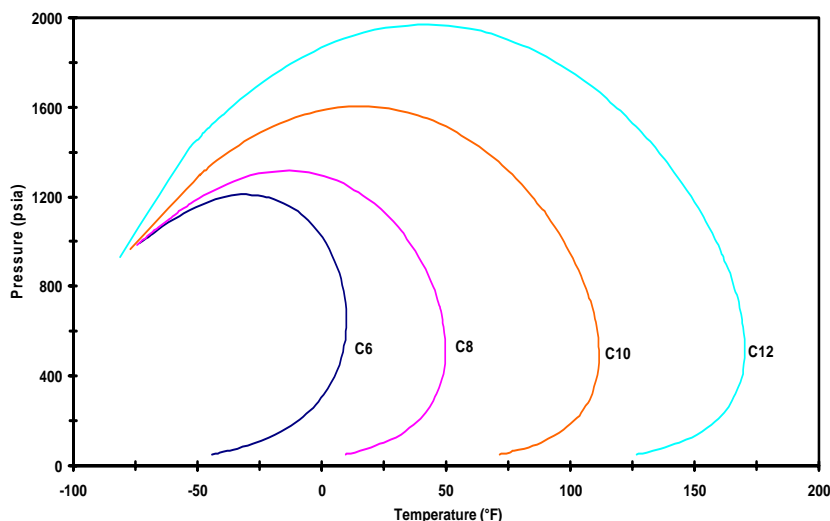

Figure 2 - Impact of C₆₊ Content on Hydrocarbon Dew Point
(Lean gas with 450 ppm C₆, C₈, C₁₀, or C₁₂)

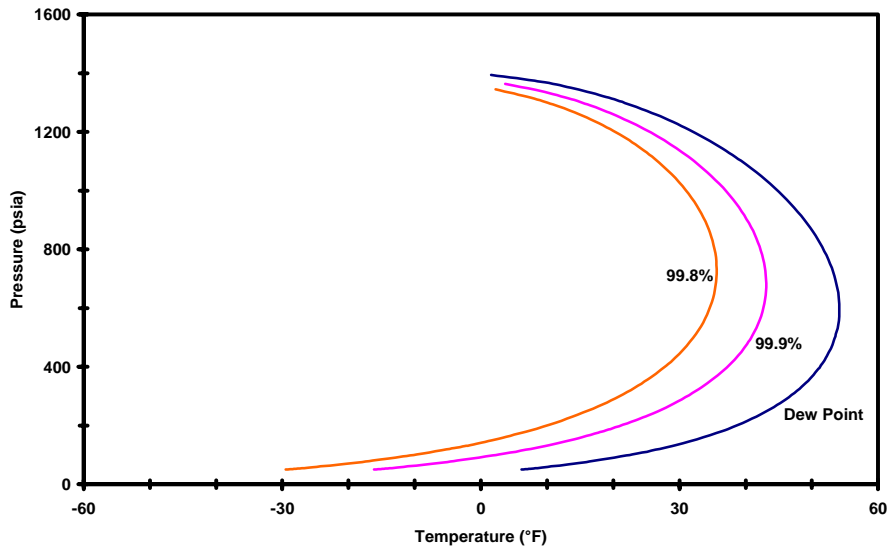

Figure 3a - Phase Envelope with Quality Lines for Rich Gas

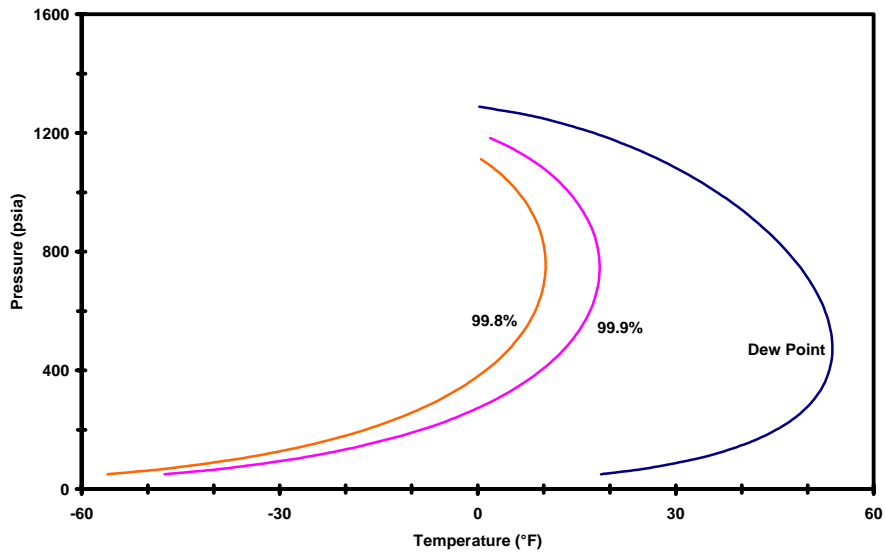

Figure 3b - Phase Envelope with Quality Lines for Lean Gas with Compressor Oil

The most convenient method of determining the impact of liquids in transmission lines is to set up a simulation of each line. For a given set of conditions, the simulation will calculate the liquid holdup, pressure drop and compressor horsepower. From this information, decisions can be made on the best course of action including (1) determining pigging frequency to reduce the compression cost and increase throughput and (2) more closely monitoring the quality of the incoming gas and working with the suppliers to reduce the amount of liquids in the line.

A case study of the impact of liquids in pipelines was made on a fifty mile section of a 36 inch operating pipeline with an elevation profile as shown in Figure 4. The steepest slopes in the pipeline were about 3° . Using Bryan Research & Engineering's ProMax[®] [8] process simulator, the line was simulated with varying amounts of liquid for gas throughputs of 100, 300 and 450 MMSCFD with an inlet pressure of 670 psia. The corresponding line velocities at the inlet were 6.5, 18 and 28 ft/sec, respectively. As shown in Figure 5, small amounts of liquids would have only a modest impact on pressure drops at low gas velocities. However, at moderate to high gas velocities, liquid volumes as low as 0.1 vol. % can have a major impact on the pressure drop and resulting required horsepower.

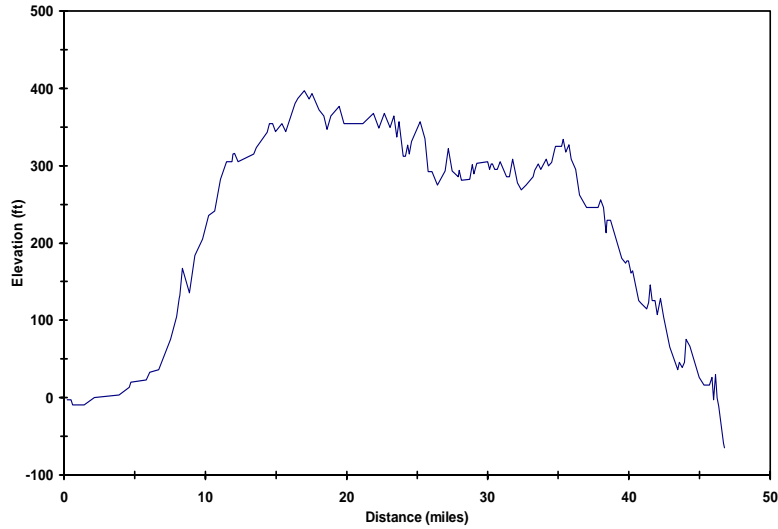

Figure 4 - Pipeline Elevation Profile

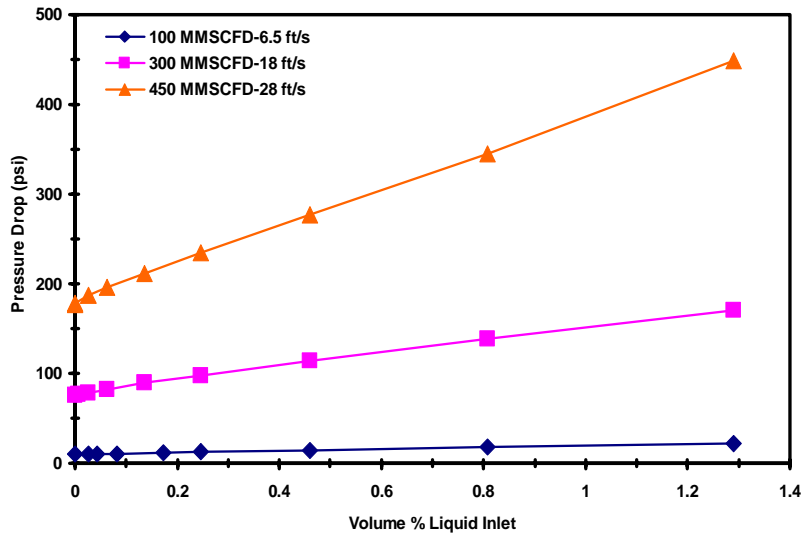

Figure 5 - Effect of Liquids on Pressure Drop in a 36 inch Pipeline at Various Gas Volumes

Distribution Lines

In general, distribution lines have minimal separation facilities for liquids. Thus special care must be taken to ensure that no liquids enter the distribution system and that none is formed through retrograde condensation while dropping the pressure from the transmission line to the distribution system, or through ambient cooling of the gas in the distribution system. This may be accomplished by adequate upstream separation and by ensuring that the coldest point in the distribution system remains above the dew point temperature. The JT coefficient of natural gas which is mostly methane is approximately 7°F/100 psi. Figure 1 shows the adiabatic choke curve followed by a gas being throttled from 800 psia and 70°F down to 50 psia. As can be seen, the gas will cool to 20°F, even if the ambient temperature is 70°F. And, in doing so, the gas will pass through the dew point line and condense liquids. Thus, a phase diagram such as the one shown in Figure 1 should be studied to ensure that no condensation occurs through retrograde or sensible cooling. In some cases, heating of

the gas may be necessary to avoid condensation. In any case, gas with a lower HCDP will tend to prevent liquids.

DETERMINATION OF HYDROCARBON DEW POINTS

The common methods used to determine hydrocarbon dew points (HCDP) are direct measurement using a chilled mirror procedure and indirect measurement using compositional analysis from a gas chromatograph (GC) combined with an equation of state (EOS). These methods are discussed below:

Chilled Mirror Method

This method is conceptually quite simple and consists of flowing a gas stream past a mirror that is being cooled or chilled. The temperature at which the first condensation or dew is observed on the mirror is the dew point. Warner et al [2] performed an extensive round-robin study on HCDP using the chilled mirror method. HCDP's were observed for seven lean gas mixtures by ten different operators for a total of 80 observations in the study. Certified gas standards were used for five of the gases. The results for the study showed that (1) the average spread (maximum HCDP-Minimum HCDP) in the observation for the seven gases was 13.5°F, (2) the average standard deviation was 3.4°F and (3) the average precision for the observers was 2.4°F.

The Warner et al [2] study was made for lean gas mixtures having a large number of components in the C₆+ range. The study was performed in the laboratory under controlled conditions with gases that were prepared in the laboratory and contained no water or other contaminants such as glycols or compressor oils. In a typical pipeline application, a number of additional factors would need to be considered. These include the operation of the apparatus in a field environment as well as the presence of water, glycols, compressor oils, and other components which can condense and interfere with or mask the HCDP. According to ASTM [5], when interference might be a problem, it is sometimes very helpful to supplement the apparatus with an optical attachment that uniformly illuminates the dew point mirror and magnifies the condensate on the mirror. With this attachment it is possible, in some cases, to observe separate condensation points of water vapor, hydrocarbons, glycol, and amines as well as ice points. Obviously, the dew point as measured by the chilled mirror method must be slightly lower than the true dew point to permit a visible or detectable film on the mirror.

The manual procedure for the chilled mirror method may require up to one hour of uninterrupted attention by the operator. Although automated continuous units are available, they are expensive and, unlike gas chromatographs, they are currently not part of the existing gas transmission infrastructure (NGC-GPA White Paper [3]). In addition, the determination of the phase envelope or the cricondentherm (maximum HCDP) would be difficult using this method since a series of measurements at various pressures would be required. The chilled mirror method yields the best results when tests are performed by qualified operators. This is especially true since the chilled mirror method relies on the operator to make a subjective determination of the point when hydrocarbons begin to condense on the mirror. Care must be taken by the operator not to mistake the condensation of other substances (e.g. glycol and water) for the hydrocarbon condensation.

Gas Chromatography - Equation of State (GC-EOS) Method

This method uses a gas chromatograph (GC) for compositional analysis in conjunction with an equation of state (EOS) to calculate the dew point as well as the cricondentherm and phase envelope if desired. For the most part, the accuracy of the method depends on the determination of the C₆+

components which are typically determined using one of two methods. The first method involves a standard GC analysis for composition through C₆₊ using GPA 2261 procedure [10] combined with a procedure to characterize the C₆₊ fractions as suggested by Moshfeghian et al [11] and Voulgaris et al [7] and Daniels [12].

The second method for the C₆₊ determination is accomplished from either a C₉₊ analysis or an extended analysis of the components from a gas chromatography (GC) using GPA 2286 procedures [13]. Either a Peng-Robinson (PR) or Soave-Redlich-Kwong (SRK) equation of state is typically used for the calculations. In this work, ProMax process simulation software by Bryan Research & Engineering, Inc. was used for all calculations.

Extended GC analyses by seven different laboratories using the GPA 2286 procedure for seven lean natural gas mixtures were also included in the study by Warner et al [2]. As discussed above in the chilled mirror study by Warner et al [2], the GC study was performed in the laboratory under controlled conditions with gases prepared in the laboratory and containing no water or other contaminants such as glycols or compressor oils. The average relative standard deviations for C₈, C₉ and C₁₀ component measurements were 7.6, 28.5 and 55.6%, respectively, with greater than 100% for heavier compounds. Based on 147 observations, they concluded that the accuracy of the GC-EOS method for gases containing up to C₁₂'s was about 34°F. Obviously, for gases containing up to C₉'s, the accuracy would be much better.

Other studies have found good accuracy with the GC-EOS method. For example, Ernest and Pettigrew [6] have noted a relative standard deviation for C₉₊ to be 2.4% at the 2 ppm level. They also compared the GC-EOS method to the chilled mirror method at two sites. At the first site, the GC-EOS value was 5.7°F compared to -4°F by chilled mirror for a 1,014 BTU/SCF gas. At the second site, they found the differences to be less than 4°F for most measurements with 6°F being the largest.

Confirmation of GC-EOS method

As discussed in the section above on the chilled mirror method, Warner et al [2] used five certified gas standards for measurement of the HCDP by the chilled mirror method. The composition of a certified gas standard is determined by weight and not by GC. The compositions for these five certified gas standards were not reported in Warner et al [2] and were not used by Warner et al to calculate the HCDP by the GC-EOS method. As part of the present study, the compositions of the five certified gases were obtained from Mr. Hal Warner [14] and ProMax was used to calculate the HCDP. As shown in Table I, the HCDP calculated by both PR and SRK agree very well with the measurements by chilled mirror. The average difference was -3.0 and 0.4°F for PR and SRK equations of state in ProMax, respectively. These values agree within the accuracy of the chilled mirror measurements. Thus, with good compositional analyses, the PR and SRK equation of state options in ProMax predict HCDP within the accuracy of the chilled mirror method. Based on this limited set of observations, SRK predicts HCDP about 3 to 4°F higher than PR and matches the chilled mirror measurements slightly better.

Table I - Comparison of Hydrocarbon Dew Points from ProMax to Measurements by Chilled Mirror for Five Certified Gas Standards from Warner et al [2].

Gas¹	Avg. HCDP Dewscope °F	HCDP ProMax - PR °F	PR Diff. from Chilled Mirror	HCDP ProMax -SRK °F	SRK Diff. from Chilled Mirror
A	46	44	-2	47	+1
B	71	69	-2	72	+1
C	61	58	-3	62	+1
E	64	58	-6	62	-2
F	71	69	-2	72	+1
			Avg. -3.0		Avg. +0.4

¹From Warner et al [2], Round Robin Study #2 – Dewscope (chilled mirror method)

QUESTAR PIPELINE COMPANY

Questar Pipeline Company (QPC) owns and operates an interstate gas transmission company with facilities in Utah, Wyoming and Colorado. A map of this pipeline system with the interconnected producing basins that supply gas to the system is shown in Figure 6. QPC’s pipeline system is the antithesis of a traditional long-line pipeline and is configured more like an “H” lying on its side as can be seen in Figure 7. Largely due to the temperature sensitive distribution loads on the west end of the system, gas flows can vary greatly from season to season and from day to day. It is not uncommon to see several null points at any given time on the system.

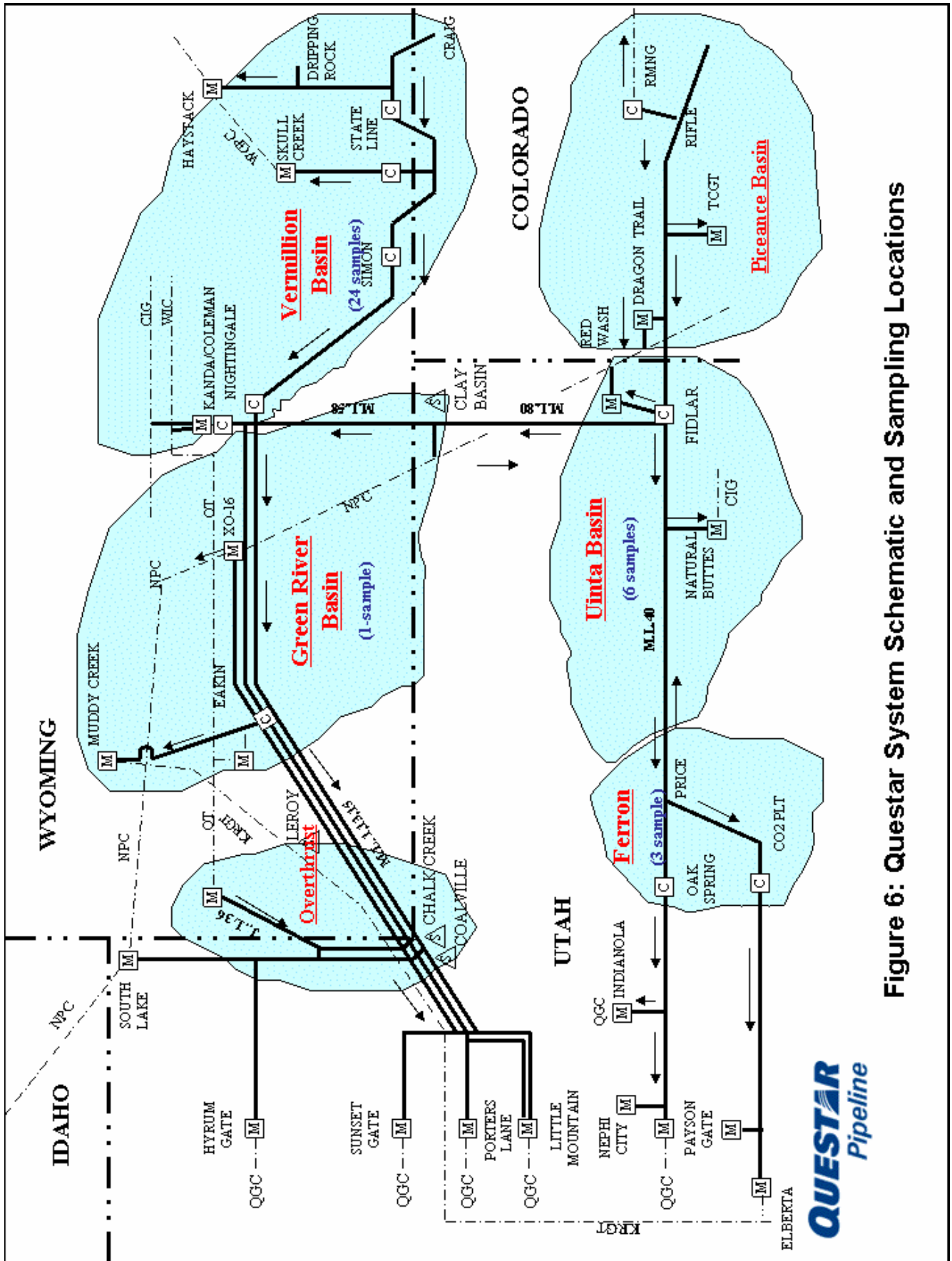

Figure 6: Questar System Schematic and Sampling Locations

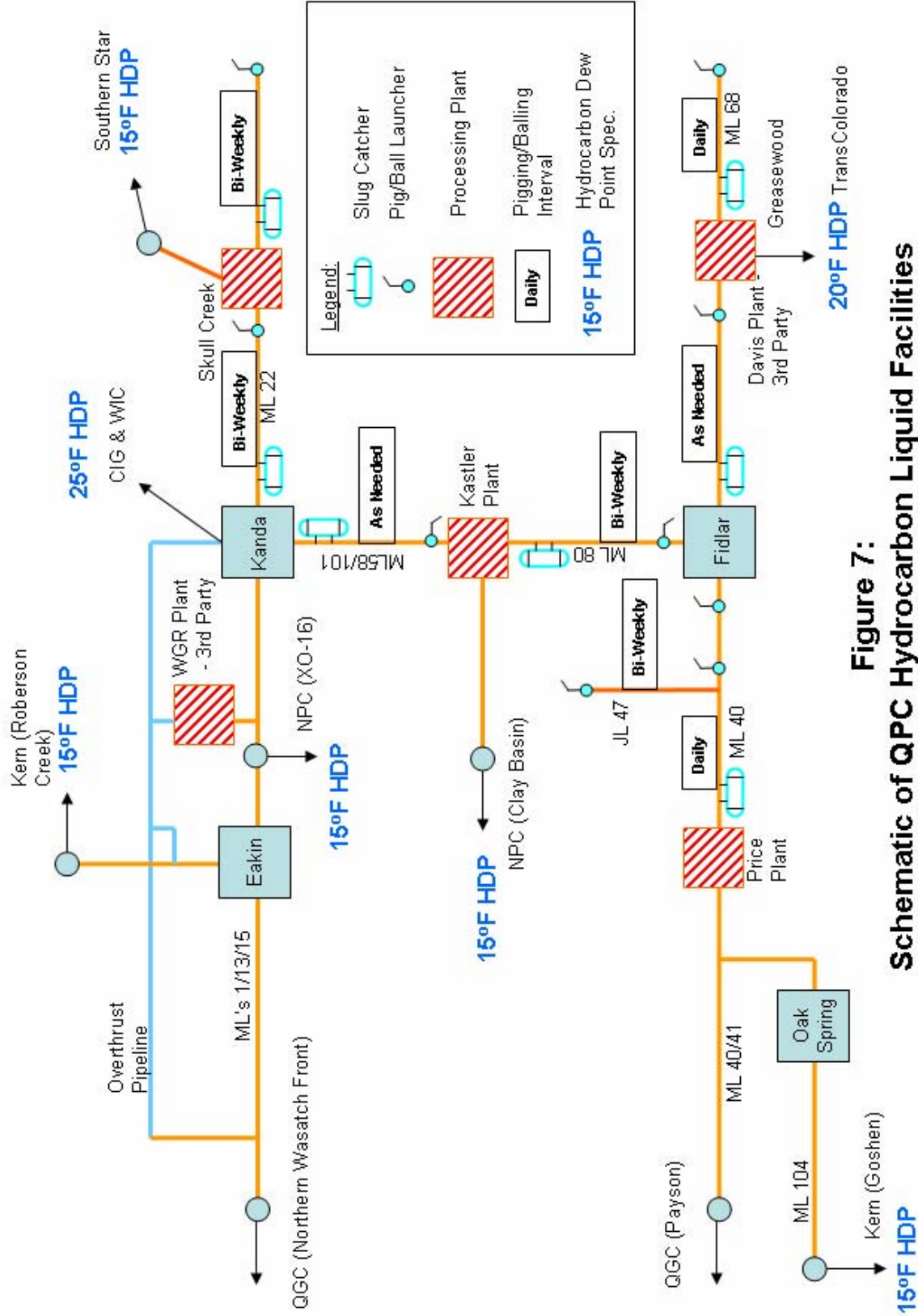

Figure 7:
Schematic of QPC Hydrocarbon Liquid Facilities

Another feature of QPC's system that differentiates it from traditional interstate pipeline systems is that portions of the system are designed and operated to handle natural gas saturated with hydrocarbon liquids. QPC has installed liquid handling facilities (pig launchers and receivers along with slug catchers) on its system along with processing plants to allow it to receive high HCDP gas and to deliver processed gas to downstream markets.

HCDP MANAGEMENT

A schematic of QPC'S system, major points of delivery, compressor stations, processing plants, and liquid handling facilities is presented in Figure 7. Also shown on the schematic are the HCDP specifications of the downstream pipelines connected to the system. QPC's ability to meet these HCDP specifications is largely dependent on operation of the straddle processing plants and QPC's ability to monitor and manage the HCDP of the gas that enters its pipeline system. Over the past several years, QPC has developed an on-line system to automatically calculate HCDP temperatures and cricondentherms at various points throughout its pipelines. This system relies on compositional data from on-line chromatographs that sample and analyze data from significant receipt, delivery and operational points throughout the pipeline system. QPC is unique in the industry in that its fleet of chromatographs are designed and operated to analyze through C₉₊ as opposed to the traditional C₆₊ which is the industry standard. The measured composition from the chromatographs is transferred to nearby flow computers where the data is then stored and transmitted to QPC's gas control server in Salt Lake City, Utah. The compositions are then fed into a dedicated server to calculate HCDP temperatures at pipeline pressure along with cricondentherms. ProMax [8], Bryan Research & Engineering, Inc.'s process simulation software package, is loaded on the HCDP server to calculate both values. HCDP values are updated once every two minutes for 271 individual sample points on the system. A schematic of the on-line HCDP calculation system is shown in Figure 8 and illustrates the data flow from the field to the end user. HCDP data are available to QPC's gas control directly through the SCADA system. Other QPC personnel can access HCDP data via PipeViewer – a web based in-house system that allows company employees to view real-time SCADA data.

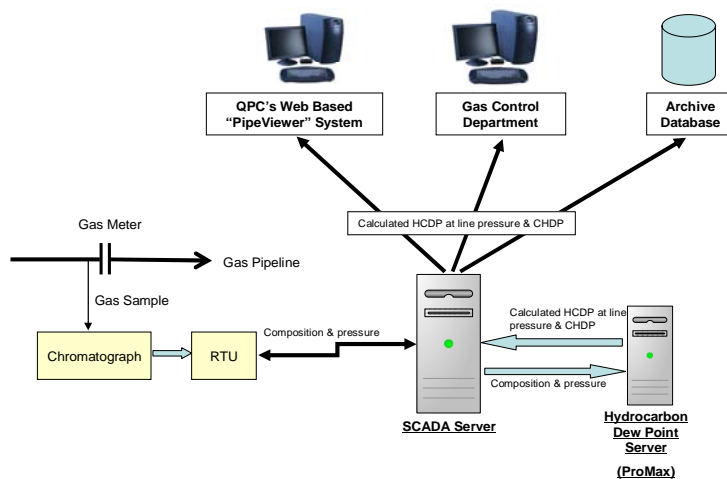

FIGURE 8: Schematic of QPC'S On-line HCDP Calculation System

QPC's gas control and field operations monitor the HCDP data closely to help set pig launching intervals used to remove free liquids in the pipe and to help maintain the correct HCDP temperature to downstream pipelines. Data from the HCDP calculation system is used to identify the points with the highest HCDP temperatures for purposes of curtailing gas. From time to time, QPC will restrict the receipt of gas from points that deliver high HCDP gas into its system. QPC's engineers and operations personnel have made extensive use of the archived data to design new facilities and to optimize operation of the system.

Sample Procedures

In the present study, Questar collected 34 sets of data on HCDP from different locations on its pipeline system. These were taken from four of the six gas fields that deliver gas into the Questar system: 1 sample from the Green River Basin, 24 samples from the Vermillion Basin, 3 samples from Ferron and 6 samples from the Uinta Basin. These locations encompass a host of gas qualities ranging from moderately wet gas to dry gas.

For each data set, hydrocarbon dew point temperatures were determined using four different methods: 1) direct measurement using a chilled mirror apparatus, 2) indirect measurement using a thermodynamic equation of state and a gas composition based on Questar's standard C₉₊ chromatograph, 3) indirect measurement using a thermodynamic equation of state and a gas composition based on an extended analysis, and 4) indirect measurement using a thermodynamic equation of state and gas composition derived from a modified C₆₊ characterization. This modified C₆₊ characterization was performed by taking the chromatograph results from method 2 above, lumping all C₆₊ components together, and redistributing assuming 47% C₆, 36% C₇, and 17% C₈ molar composition. Work conducted by a leading chromatograph manufacturer, Daniels [12], indicates that a 47:36:17 split is generally applicable. The accuracy of all gas chromatograph measurements met GPA 2186-95 standards. In addition, the water dew point for each data set was determined from the measurement of the water content of the gas along with the temperature and pressure.

Hydrocarbon dew point temperatures were calculated for methods 2, 3 and 4 above using ProMax[®] [8] with two different Equations of State (EOS): Peng Robinson (PR) and Soave-Redlich-Kwong (SRK).

Direct Measurement by Chilled Mirror

At each sample location on the pipeline network, a sample line heated to between 120°F and 140°F was connected to a Chandler Bureau of Mines dew point tester. The hydrocarbon dew point was then observed on site in the field by chilling the mirror apparatus using CO₂ as the refrigerant. The measurements were made according to ASTM D1142 procedures by four different technicians using different chilled mirror devices.

This procedure works relatively well in most cases. However, on very dry gases, the dew point tester was not capable of chilling below -40°F. The calculated dew points for some samples were significantly less than the -40°F obtained with the chilled mirror apparatus. As previously stated, it is difficult to detect the difference between a hydrocarbon dew point, water dew point, or some other compound (e.g. glycol or compressor lube oil) forming a film on the chilled mirror.

Chromatographic Analysis

C₉₊ Analysis

The C₉₊ analysis groups the C₆, C₇, C₈ and C₉ by summing the area of the peaks and assigning a response factor based on the normal isomer. The calibration standard contains only the

normal isomer and the response factor is calculated from that area. The analysis of the unknown gas automatically groups the compounds. For example, the hexane group contains the compounds from the point where the end of normal pentane elutes through normal hexane. It includes 2,2-dimethylbutane, 2,3-dimethylbutane, 2-methylpentane, 3-methylpentane and n-hexane. The C7 includes the peaks that elute after n-hexane up to n-heptane, and so on.

The on-site gas analysis, which is the Questar standard C₉₊ analysis, was obtained with a Varian 4900 micro gas chromatograph and was performed in the field along with the chilled mirror measurements. The sample delivery system to the chromatograph and the chilled mirror was heated to between 120 and 140°F.

The analyses were performed by four different technicians using the same model GC. Each of the four Varian GCs' was configured with an 8 meter capillary column and a .4 meter Haysep A column. The C₉ chromatograph quantified the following composition:

Nitrogen, Methane, Carbon Dioxide, Ethane, Propane, i-Butane, n-Butane, i-Pentane, n-Pentane, n-Hexanes, n-Heptane, n-Octanes and n-Nonanes.

Extended Analysis

The extended analysis quantified a broader range of components, especially the heavier components. Questar reported the BTEX (benzene, toluene, ethylbenzene and xylene) and n-hexane along with several other compounds. The remaining compounds were grouped in a similar manner to the C₉₊ analysis. The difference is that the BTEX compounds have their own response factors. The other compounds use the response factors of the normal isomers.

The spot samples were obtained in the field for the extended analysis using the API 14.1 purge and fill method. The cylinder was maintained between 120° and 140°F in a heated box until it was removed and insulated with a preheated wrap. A 36 inch extension tube was used for the exit throttling device to keep the JT cooling away from the cylinder. The cylinder was brought back to the lab in a heated enclosure on the truck. At the lab the cylinder was also maintained at 120°F in a heated room.

The extended analysis was done using an HP6890 chromatograph with the Wasson configuration. The extended hydrocarbon portion of the analysis was done on a 60 meter capillary column with a FID (flame ionization detector). All lines were heat traced to the chromatograph.

The following constituents were identified as part of the extended analysis:

Carbon Dioxide, Hydrogen Sulfide, Nitrogen, Methane, Ethane, Propane, Isobutane, n-Butane, Isopentane, n-Pentane, Neopentane, Cyclopentane, n-Hexane, Cyclohexane, 2,2-Dimethylbutane, 2,3-Dimethylbutane, 2-Methylpentane, 3-Methylpentane, n-Heptane, Methylcyclohexane, 2,2,4-Trimethylpentane, Benzene, Toluene, Ethylbenzene, m-Xylene, n-Octane, n-Nonane

RESULTS AND DISCUSSION

For each of the 34 data sets, the field, sample location, pipeline pressure, water dew point and various HCDP's are presented in Table II. The HCDP's consist of direct measurement by the chilled mirror method and by calculations using the PR and SRK equations of state for the three gas compositions : 1) standard C₉₊ analysis, 2) extended analysis, and 3) modified C₆₊ characterization using 47% C₆, 36% C₇, and 17% C₈. The reader should remember that data for this study were not collected in a controlled laboratory setting but were rather gathered in the field under typical operating conditions. This approach undoubtedly introduces more variability into the analysis but alternatively, results from the study should more closely reflect the conditions under which most pipelines operate.

Table II - Field Sample Summary- Chilled Mirror and Calculated HCDP

Meter Name	Field	Sample Location	Pipeline Pressure psi	Tech-nician	Sample Date (2005)	HCDP Chilled Mirror (deg F)	Water Dew Point (deg F)	C9+ PR	Extended PR	C9+ SRK	Extended SRK	C6+ Character PR	C6+ Character SRK
Cottonwood Wash	Uinta	DP609	787	1	4/20	28	4	32	27	37	32	37	43
Cottonwood Wash	Uinta	DP609	800	1	5/18	35	8.2	26	28	31	32	36	42
North Monument Butte	Uinta	DP4763	722	1	4/19	32	-5	51	31	57	36	46	52
North Monument Butte	Uinta	DP4763	806	1	5/19	65	-5	69	71	74	76	76	82
Cottonwood Wash	Uinta	DP609	772	1	6/20	31	4	35	28	40	33	39	45
North Monument Butte	Uinta	DP4763	788	1	6/20	34	4	48	37	54	42	46	51
Blacks Fork	Green River	DP4533	670	2	7/25	47	19	54	40	59	45	45	50
Helper Federal	Ferron	DP4476	652	3	4/19	-24*	22	-112	-112	-112	-111	-112	-112
Helper Federal	Ferron	DP4476	676	3	5/20	-35*	8	-110	-48	-110	-40	-110	-110
Helper Federal	Ferron	DP4476	634	3	6/30	-40*	19	-112	-88	-112	-81	-112	-112
South Baggs MS#35	Vermillion	DP1248	600	2	10/13	72	32	57	55	62	60	41	46
Sand Hills Master	Vermillion	DP2853	663	2	10/13	61	25	67	55	72	60	74	78
Brady Master	Vermillion	DP4478	494	4	10/14	73	29	79	66	83	69	78	82
Salt Wells Master	Vermillion	DP7973	490	4	10/14	68	32	32	22	37	27	21	25
Middle Baxter master	Vermillion	DP4406	450	4	10/14	52	9	4	5	8	10	2	6
Powder Wash Lateral	Vermillion	DP3055	582	4	10/13	76	49	62	67	65	70	68	72
Powder wash Master	Vermillion	DP1126	577	4	10/13	69	3	61	56	65	59	70	74
Mulligan #6 tap	Vermillion	DP3780	708	4	10/19	69	26	31	53	36	58	39	44
Mulligan #27	Vermillion	DP4621	746	4	10/20	32*	19	-50	-27	-44	-20	-74	-67
Mulligan #4	Vermillion	DP4246	750	4	10/20	73	44	51	57	57	63	41	47
Wedge #5 tap	Vermillion	DP7986	727	4	10/20	76	34	60	66	65	71	52	57
Mulligan #1	Vermillion	DP3925	725	4	10/19	82	19	36	41	41	46	41	46
Mulligan Federal	Vermillion	DP7902	717	4	10/19	79	29	54	69	60	74	51	57
Mulligan #15	Vermillion	DP4356	725	4	10/19	79	32	44	54	50	59	46	51
Lateral #326	Vermillion	DP1354	643	4	10/18	58	28	27	27	33	33	22	27
Baker Peak Tap	Vermillion	DP722	644	4	10/18	77	33	53	48	58	52	55	60
Wedge #3	Vermillion	DP6237	747	4	10/20	79	21	38	41	44	47	33	39
Sand Hills Battle Mtn	Vermillion	DP2853	668	4	10/17	66	27	55	55	60	59	65	70
Blue Gravel tap	Vermillion	DP3960	719	4	10/17	75	26	69	68	74	72	67	72
Hiawatha Deep	Vermillion	DP740	526	4	10/13	35*	18	-13	-8	-8	-2	-28	-23
Chandler MS #149	Vermillion	DP983	676	4	10/18	84	39	84	74	89	78	78	83
Timber Lake Tap	Vermillion	DP4728	680	4	10/17	86	35	53	58	58	62	61	66
Blue Water tap	Vermillion	DP737	535	4	10/13	64	26	43	37	48	42	22	27
North Craig MS#46	Vermillion	DP981	661	4	10/18	75	28	54	50	59	54	57	62

* Excluded from further analysis due to water dew point.

In Table II, the five data sets with an asterisk next to the value for HCDP by chilled mirror had HCDP's that were near or below the water dew point. Furthermore, three of these five data sets were from the Ferron Field and were apparently near or below the cooling limit of -40°F for the chilled mirror device. In addition, the HCDP's from both the C_9+ and extended analyses were far below the chilled mirror value. Thus, it appears that the cooling limit for the chilled mirror device and/or the water dew point interfered with the measurement of the HCDP by chilled mirror for these five data sets. As a result, these data sets were not used in further analysis and discussion in the present work.

The HCDP as determined from the C_9+ and extended analyses agree very well for the PR equation of state as shown in Figure 9 and for SRK as shown in Figure 10. If the C_9+ and extended values for HCDP agreed exactly, the point would fall on the 45° line. As shown in these figures and Table II, about 80% of the HCDP values determined from the C_9+ and extended analyses agree within 10°F and 95% agree within about 12°F . This is excellent agreement, especially considering that the C_9+ analyses were performed on-site at the sample locations and by four different technicians using different Varian GC's of the same model. In addition, the extended analysis samples were collected, transported to the central laboratory, and analyzed using a Hewlett Packard GC. The excellent agreement between the HCDP based on the C_9+ and extended analyses combined with the use of different sample handling procedures and different GC's lends a great deal of credibility to the HCDP values by the GC-EOS methods.

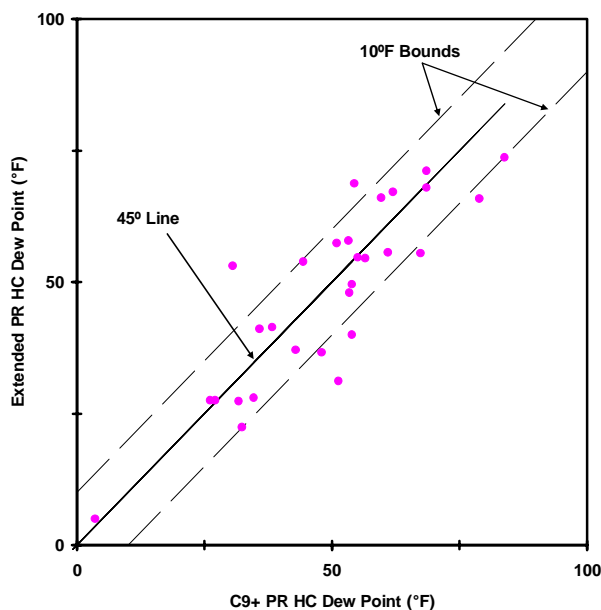

Figure 9 - Comparison of Hydrocarbon Dew Points Using C_9+ and Extended Analyses with PR EOS

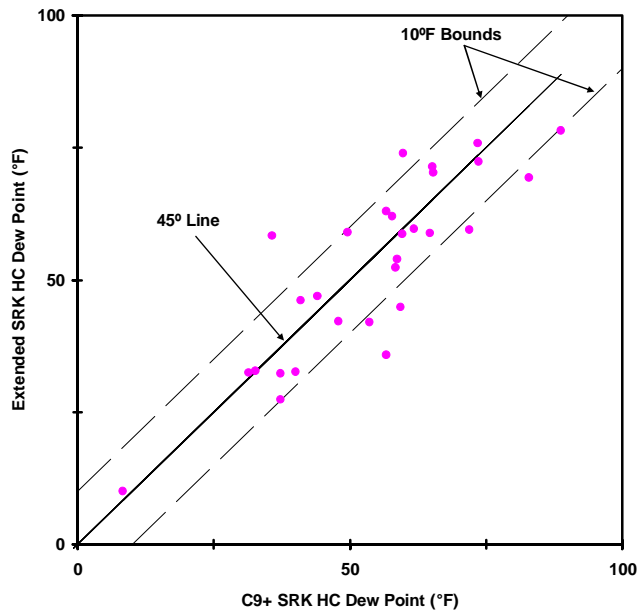

Figure 10 - Comparison of Hydrocarbon Dew Points Using C_9+ and Extended Analyses with SRK EOS

The HCDP values by the chilled mirror method are compared to the values by each of the GC methods using PR in Figures 11 through 13. The results from using each GC-SRK combination were virtually the same but with HCDP's about 3 to 4°F higher than for PR. As can be seen from Figures 11 through 13, the agreement between the chilled mirror and GC-EOS values is good for some points and quite poor for others. For 30 to 40% of the data sets, the chilled mirror values were more than 20°F higher than the GC-EOS values. In a field study such as the present, agreement within about 10 to 12°F between the chilled mirror and GC-EOS methods would be expected. As stated above, the excellent agreement between the C_9+ and extended analyses lends credibility to the values by GC-EOS. Thus, a detailed investigation was undertaken to determine why a significant number of the values by chilled mirror were more than 10 to 12°F higher than by GC-EOS. A number of factors were

considered including: 1) the location of dehydration units and compressor stations for possible contamination by glycols and compressor oils, and 2) the technicians performing the test.

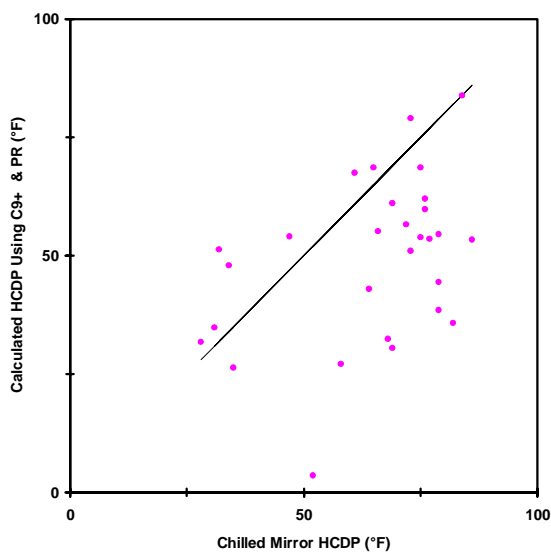

Figure 11 - Comparison of Hydrocarbon Dew Points by Chilled Mirror to Calculated Using C9+ Analysis and PR

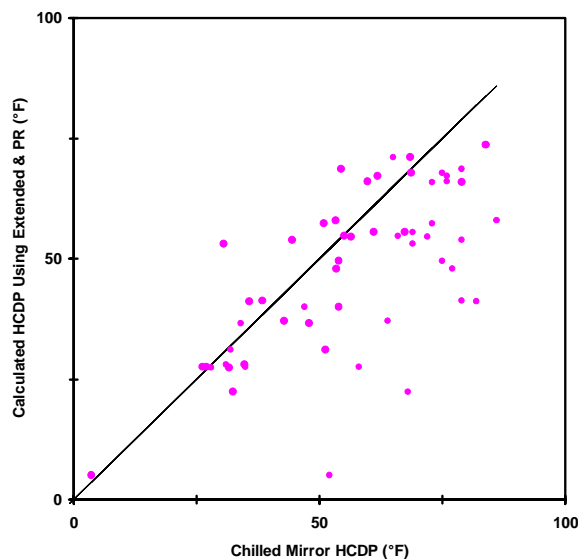

Figure 12 - Comparison of Hydrocarbon Dew Points by Chilled Mirror to Extended Analysis and PR

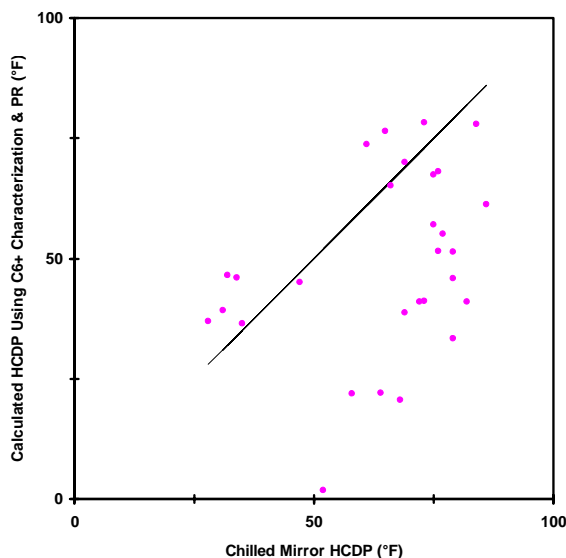

Figure 13 - Comparison of Hydrocarbon Dew Points by Chilled Mirror to C6+ Characterization and PR

The investigation led to examining the distribution of the differences between HCDP by chilled mirror and GC-EOS methods for each technician. Of the 29 data sets used in the present study, Technicians 1 and 2 collected 9 sets and Technician 4 collected 20 sets. As shown in Figure 14, the agreement between the chilled mirror and GC-EOS values by Technicians 1 and 2 are within the expected limits of about 10 to 12°F depending upon the GC-EOS combination. Out of the nine data sets, only one set resulted in a difference between chilled mirror and GC-EOS values greater than 20°F for certain GC-EOS combinations. As expected, the extended analysis gave slightly better results than the C₉₊. Also as expected, the agreement for the values from the C₆₊ characterization were not as good as from the C₉₊ and extended analysis for Technicians 1 and 2.

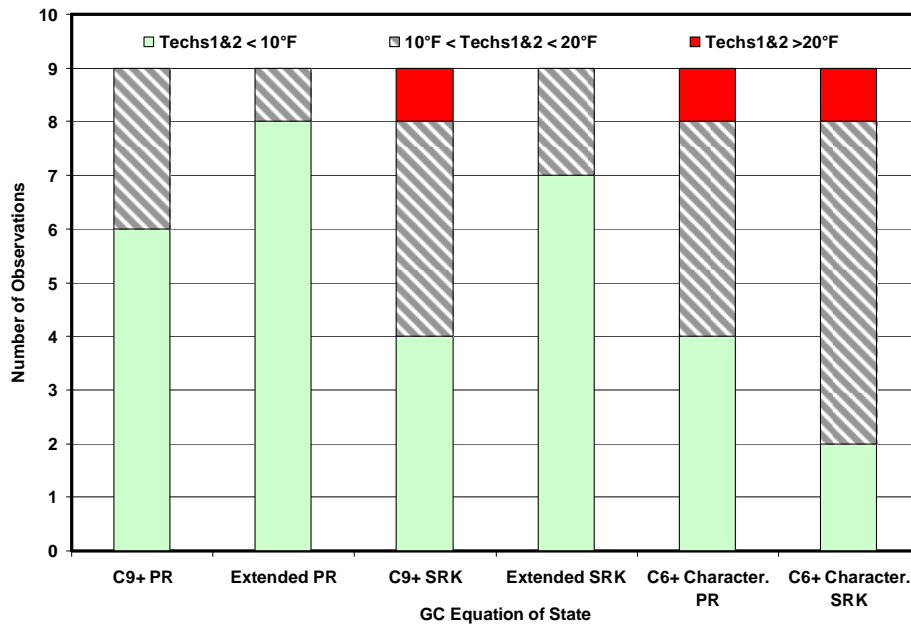

Figure 14 - Comparison of HCDP by GC-EOS to Chilled Mirror for Technicians 1 & 2

Of the 20 sets of data collected by Technician 4, the agreement between chilled mirror and the GC-EOS values was within the expected limit for only 4 to 6 sets depending on the GC-EOS combination as shown in Figure 15. As can also be seen from this figure, about half of the chilled mirror and GC-EOS values differed by more than 20°F for Technician 4. As shown in Table II, of the six days that Technician 4 collected data, three sets were collected each day for two days and four sets were collected each day for four days. For each data set, the technician measured the HCDP by chilled mirror, ran the C₉+ GC analysis in the field and collected a gas sample for the extended GC analysis. Thus, it appears that Technician 4 was rushed and probably did not take adequate time in performing the chilled mirror measurement.

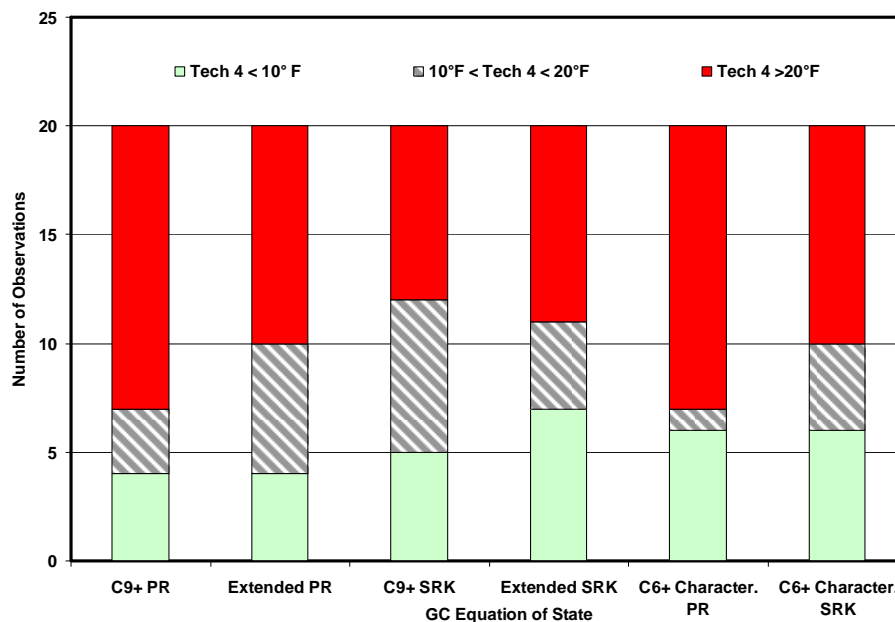

Figure 15 - Comparison of HCDP by GC-EOS to Chilled Mirror for Technician 4

SUMMARY AND CONCLUSIONS

In recent years, reduced price spreads between natural gas and natural gas liquids have resulted in the introduction of additional heavier hydrocarbons into downstream pipelines and increased concern over management of liquid fallout. In some cases, liquids in amounts as small as 0.1 vol% of the gas can have a major impact on the pressure drop in pipelines. In addition, liquids can cause problems such as flame extinguishing, overfiring, and damage to gas turbines.

The common methods used to determine hydrocarbon dew points (HCDP) are direct measurement by chilled mirror procedure and indirect measurement using compositional analysis by gas chromatograph (GC) combined with an equation of state (EOS). Based on five certified gases with compositions determined by weight, the PR & SRK EOS's in ProMax were shown to predict HCDP within the accuracy of the chilled mirror method.

Questar Pipeline Company monitors its pipeline system in Utah, Wyoming and Colorado with GC's and manages the systems based on HCDP. Questar conducted a study on HCDP from different locations on its pipeline system using four technicians. At each sample location, HCDP's were determined using four different methods: 1) chilled mirror apparatus, 2) C₉₊ analysis and EOS, 3) extended analysis and EOS and 4) C₆₊ characterization and EOS. The HCDP from the C₉₊ and extended analyses matched within the expected limits of about 10 to 12°F for 95% of the data sets. When compared to the HCDP by chilled mirror, some of the data sets matched within the expected 10 to 12°F. However, for about a third of the data sets, the chilled mirror values were more than 20°F higher than the GC-EOS values. A detailed investigation found that the agreement between the chilled mirror and GC-EOS values were within the expected limits of 10 to 12°F for Technicians 1 and 2 and that essentially all of the values differing more than 20°F were collected by Technician 4 who was apparently rushed during data collection. The study has clearly shown that HCDP measurements can vary widely, but with proper care, agreement within the expected limits of 10 to 12°F between the chilled mirror and GC-EOS methods can be achieved in a field monitoring application.

ACKNOWLEDGEMENT

The authors wish to express their appreciation to Lili Lyddon and John Polasek of Bryan Research & Engineering, Inc. for their help and contributions to the paper. Also, the authors would like to express their appreciation to Andrew Tomich and his staff of Questar Applied Technology Services for their help in collecting and preparing gas samples, performing the chromatographic analytical work, and taking the chilled mirror dew point measurements that were used in this paper.

REFERENCES CITED

1. Bergman, D.F., Tek, M.R. and Katz, D.L., Retrograde Condensation in Natural Gas Pipelines, Arlington, Virginia, American Gas Association, 1975.
2. Warner, Jr., H.R., Leamer, E.E., Spence, A.P., Bone, R.L., Hubbard, R.A., Bernos, J. and Kriel W.A., "Hydrocarbon Dew Point Determination of Lean Natural Gases," Proceedings of the 80th Annual meeting, Gas Processors Association, San Antonio, Texas, March 2001.
3. "White Paper on Liquid Hydrocarbon Dropout in Natural Gas Infrastructure," Natural Gas Council for the Federal Energy Regulatory Commission, NGC+ Liquid Hydrocarbon Dropout Task Group, October 15, 2004.
4. "Gas Quality, Hydrocarbon Dew Point (HDP), Interchangeability," Gas Processors Association Federal Subcommittee Issue Brief-Gas Quality, PL04-3, February 3, 2005.
5. Fatica, Al, "Gas-quality Debate Heats Up as More US LNG Imports Loom," *Oil & Gas Journal*, pp. 69-74, June 14, 2004.
6. Ernest, Kevin and Pettigrew, Douglas," Hydrocarbon Dew Point Monitoring of Natural Gas Using Field-Mounted, On-line Gas Chromatographs," *Pipeline & Gas Journal*, July 2005.
7. Voulgaris, M.E., Peters, C.J., De Swan Arons, J., Derks, P.A., Janssen, R. and Smit, A.L.C., "Prediction of the Potential Hydrocarbon Liquid Content of Lean Natural Gas Comparison with Field Tests," Proceedings of the 73rd Gas Processors Association Annual Convention, pp. 40-48.
8. ProMax Version 1.2, Process Simulation Software by Bryan Research & Engineering, Inc., Bryan, Texas, 2005.
9. ASTM D1142-95 (2000). "Standard Test Method for Water Vapor Content of Gaseous Fuels by Measurement of Dew Point Temperature."
10. GPA 2261, "Analysis for Natural Gas and Similar Gaseous Mixtures by Gas Chromatography," Gas Processors Association, Tulsa, Oklahoma.
11. Moshfeghian, Mahmood, Lilly, Larry L., Maddox, Robert N. and Nasrifar, Khashayar, "Study Compares C₆₊ Characterization Methods for Natural Gas Phase Envelopes," *Oil & Gas Journal*, 60-64, November 21, 2005.
12. Daniels, a Division of Emerson Electric, Standard configurations programmed into Daniels Chromatographs.
13. GPA 2286, "Tentative Method of Extended Analysis for Natural Gas and Similar Gaseous Mixtures by Temperature Programmed Gas Chromatography," Gas Processors Association, Tulsa, Oklahoma.
14. Warner, Hal, private communication dated January 14, 2006 and January 21, 2006.